

THE MATERIAL IN THIS DRAWING IS THE SOLE PROPERTY OF STORAGE MOTION INC. ANY REPRODUCTION, DISTRIBUTION AND UTILIZATION OF THIS DOCUMENT AS WELL AS COMMUNICATION OF ITS CONTENTS TO OTHERS WITHOUT EXPRESS AUTHORIZATION OF STORAGE MOTION INC. IS PROHIBITED.

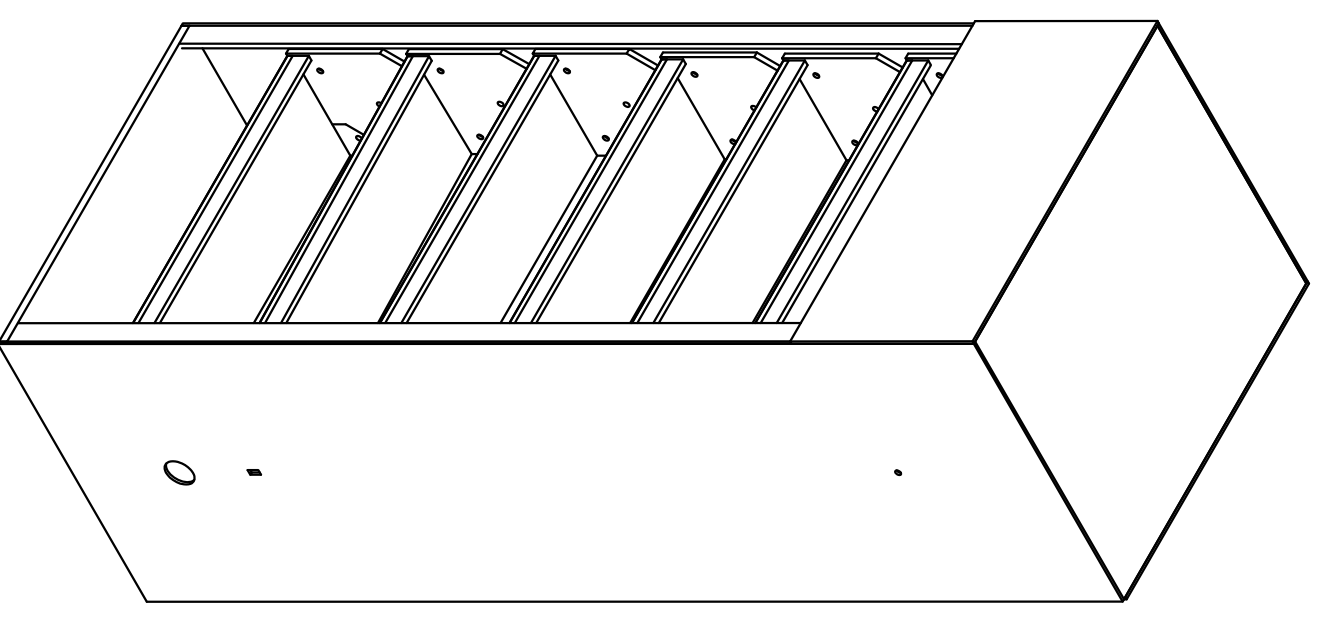
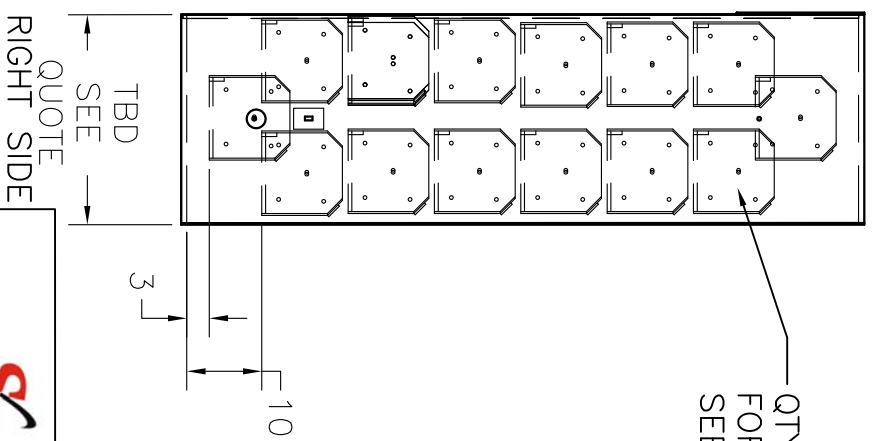
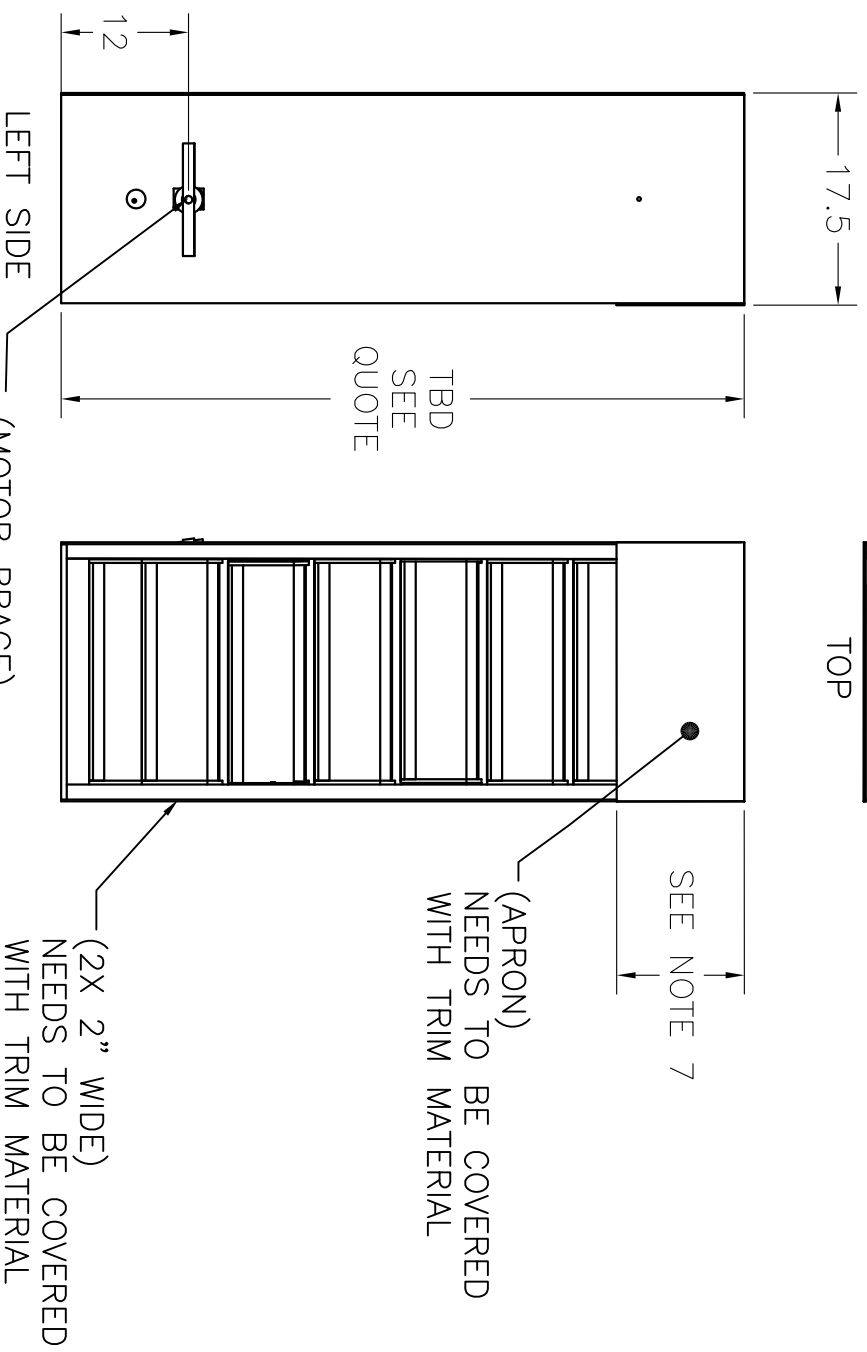
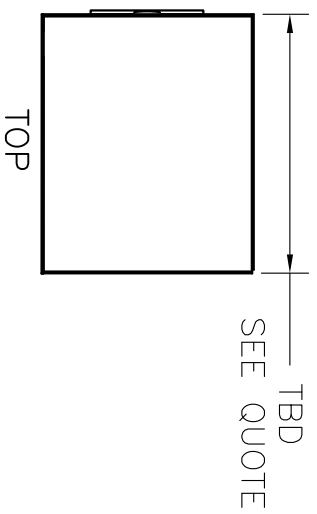

DRAWN BY: AJA

CHECKED BY: KURT K

DATE DRAWN: 8-28-16

CHECKED DATE:

ALL DIMS IN INCHES
UNLESS OTHERWISE SPECIFIED

VERTICAL CAROUSEL
(AUTO PANTRY)
18 SYSTEM

STORAGE MOTION INC.

MOORESVILLE NC.

SIZE MATERIAL
B AS BUILT

DWG NO
2016015

SCALE N/A

FINISH -

SHEET 1 OF 1

NOTE:

1. OVERALL DIMENSIONS INCLUDE ALL CARRIAGE BOLT HEADS, BRACES, SCREW HEADS ECT.
2. UNITS ARE FULLY ASSEMBLED WHEN SHIPPED.
3. 110 VOLT MOMENTARY WALL SWITCH WITH SWITCH PLATE IS PROVIDED AND MUST BE LOCATED OUTSIDE THE UNIT.
4. 2 AMP MOTOR IS LOCATED ON INSIDE OF UNIT BETWEEN THE SHELVES.
5. ONLY THE SHELVES ARE FINISHED. THE INSIDE OF THE UNIT IS PAINTED FLAT BLACK. SHELVES HAVE AN ACRYLIC FRONT GAURD.
6. TRIM MATERIAL/ FACE FRAME MUST BE ADDED THAT MATCHES REST OF CLOSET.
7. SHORT UNITS: 14" APRON.
TALL UNITS: 24" APRON.
8. QUANTITY OF SHELVES IS DETERMINED IN QUOTE.