

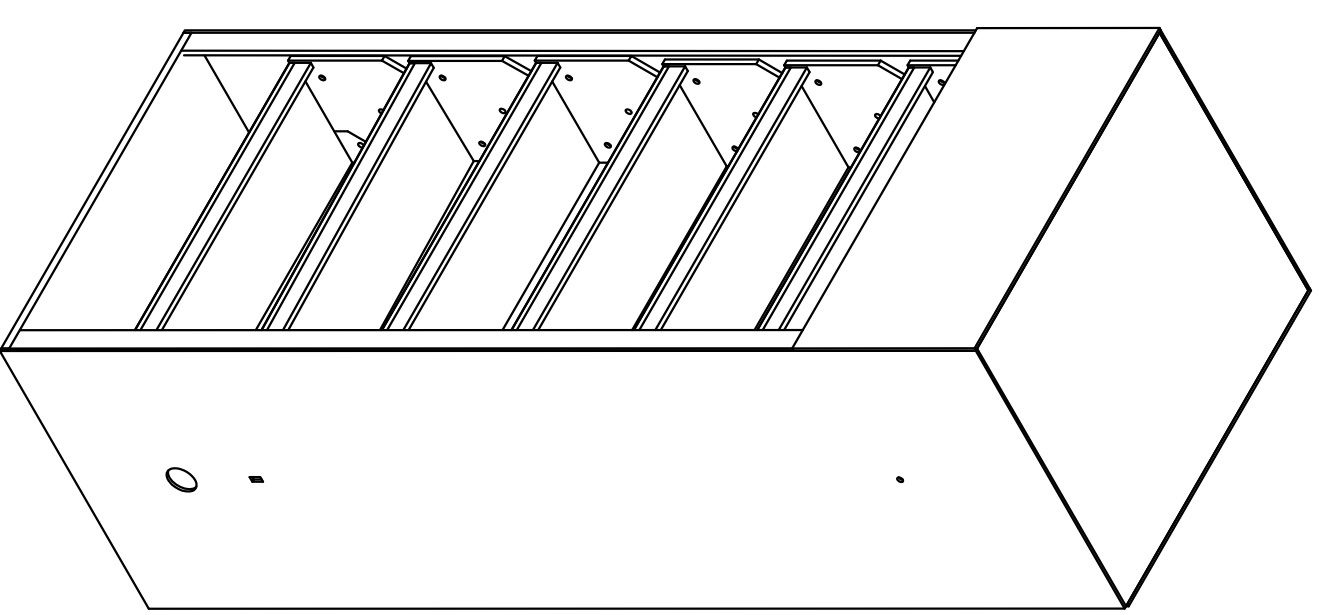

THE MATERIAL IN THIS DRAWING IS THE SOLE PROPERTY OF STORAGEOTION INC. ANY REPRODUCTION, DISTRIBUTION AND UTILIZATION OF THIS DOCUMENT AS WELL AS COMMUNICATION OF ITS CONTENTS TO OTHERS WITHOUT EXPRESS AUTHORIZATION OF STORAGEOTION INC. IS PROHIBITED.

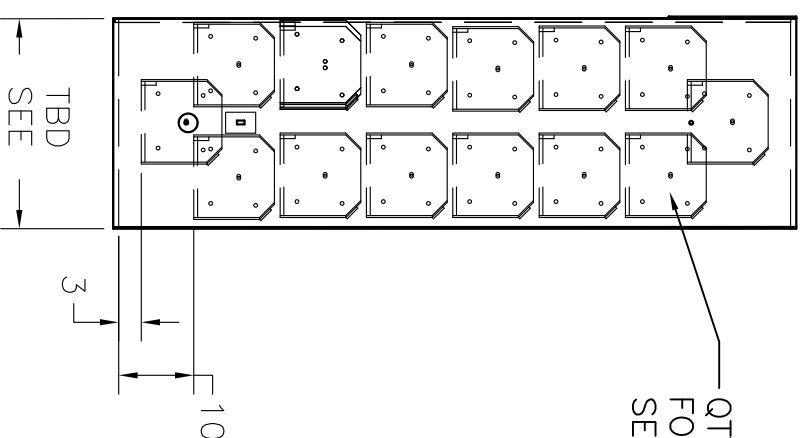
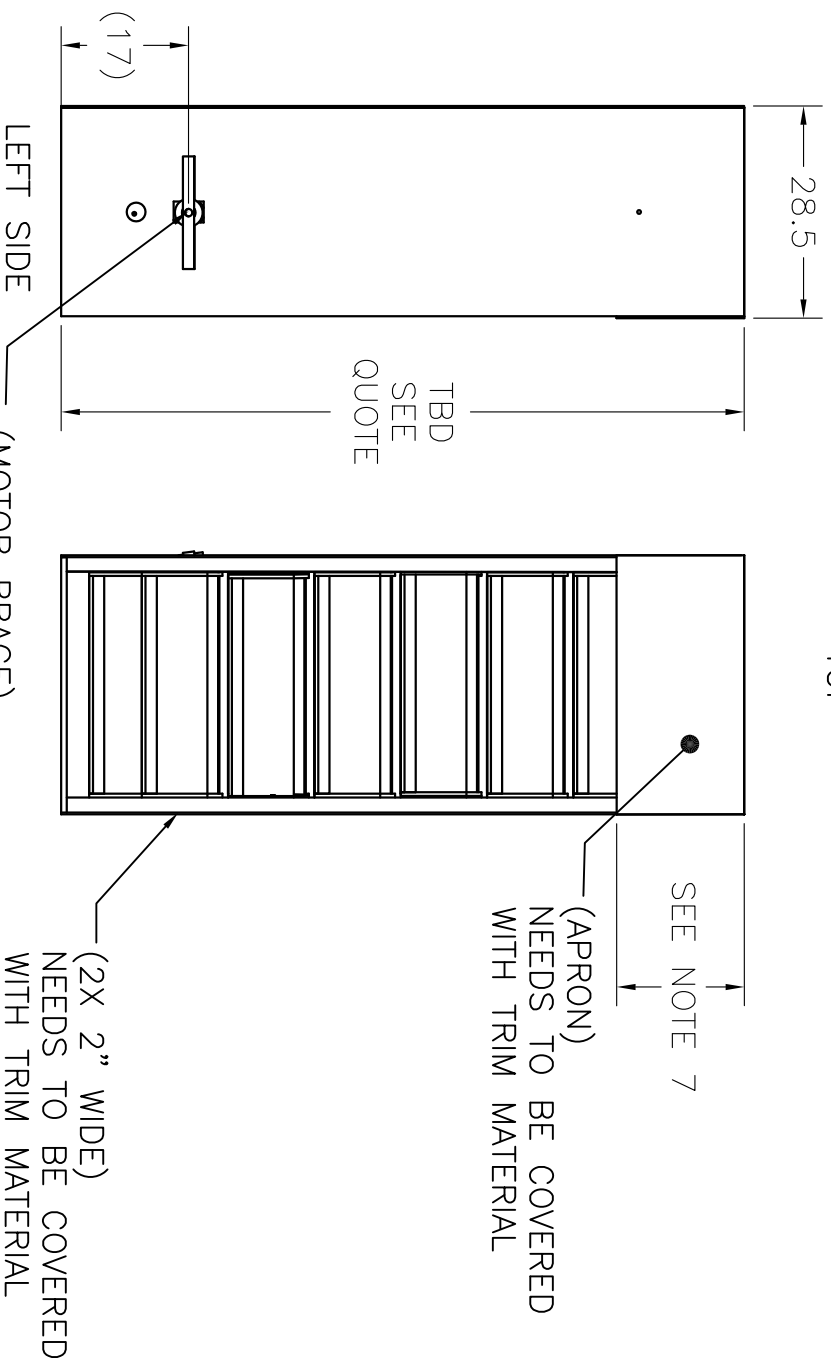
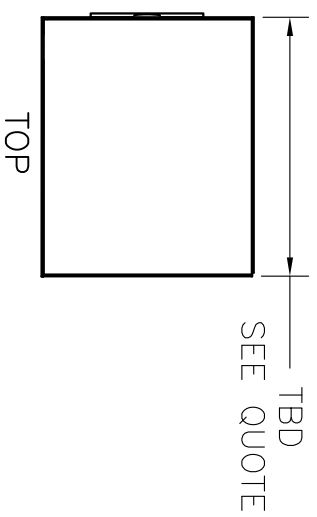

NOTE:

1. OVERALL DIMENSIONS INCLUDE ALL CARRIAGE BOLT HEADS, BRACES, SCREW HEADS ECT.
2. UNITS ARE FULLY ASSEMBLED WHEN SHIPPED.
3. 110 VOLT MOMENTARY WALL SWITCH WITH SWITCH PLATE IS PROVIDED AND MUST BE LOCATED OUTSIDE THE UNIT.
4. 2 AMP MOTOR IS LOCATED ON INSIDE OF UNIT BETWEEN THE SHELVES.
5. ONLY THE SHELVES ARE FINISHED. THE INSIDE OF THE UNIT IS PAINTED FLAT BLACK.
6. TRIM MATERIAL/ FACE FRAME MUST BE ADDED THAT MATCHES REST OF CLOSET.
7. SHORT UNITS:14" APRON.
8. TALL UNITS: 24" APRON.
8. QUANTITY OF SHELVES IS DETERMINED IN QUOTE.

 <b>STORAGEOTION™</b>		<b>VERTICAL CAROUSEL (SHOE SELECT/AUTO PANTRY) 28 SYSTEM</b>	
DRAWN BY: AJA		<b>STORAGEOTION INC.</b> MOORESVILLE NC.	
CHECKED BY: KURT K		SIZE	DWG NO
DATE DRAWN:8-28-16		B	2016015
CHECKED DATE:		MATERIAL	FINISH
ALL DIMS IN INCHES UNLESS OTHERWISE SPECIFIED		AS BUILT	-
SCALE	N/A	SHEET	1 OF 1
		REV	-