

THE MATERIAL IN THIS DRAWING IS THE SOLE PROPERTY OF STORAGEOTION INC. ANY REPRODUCTION, DISTRIBUTION AND UTILIZATION OF THIS DOCUMENT AS WELL AS COMMUNICATION OF ITS CONTENTS TO OTHERS WITHOUT EXPRESS AUTHORIZATION OF STORAGEOTION INC. IS PROHIBITED.

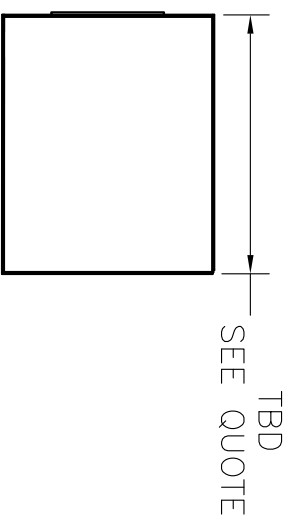

TOP

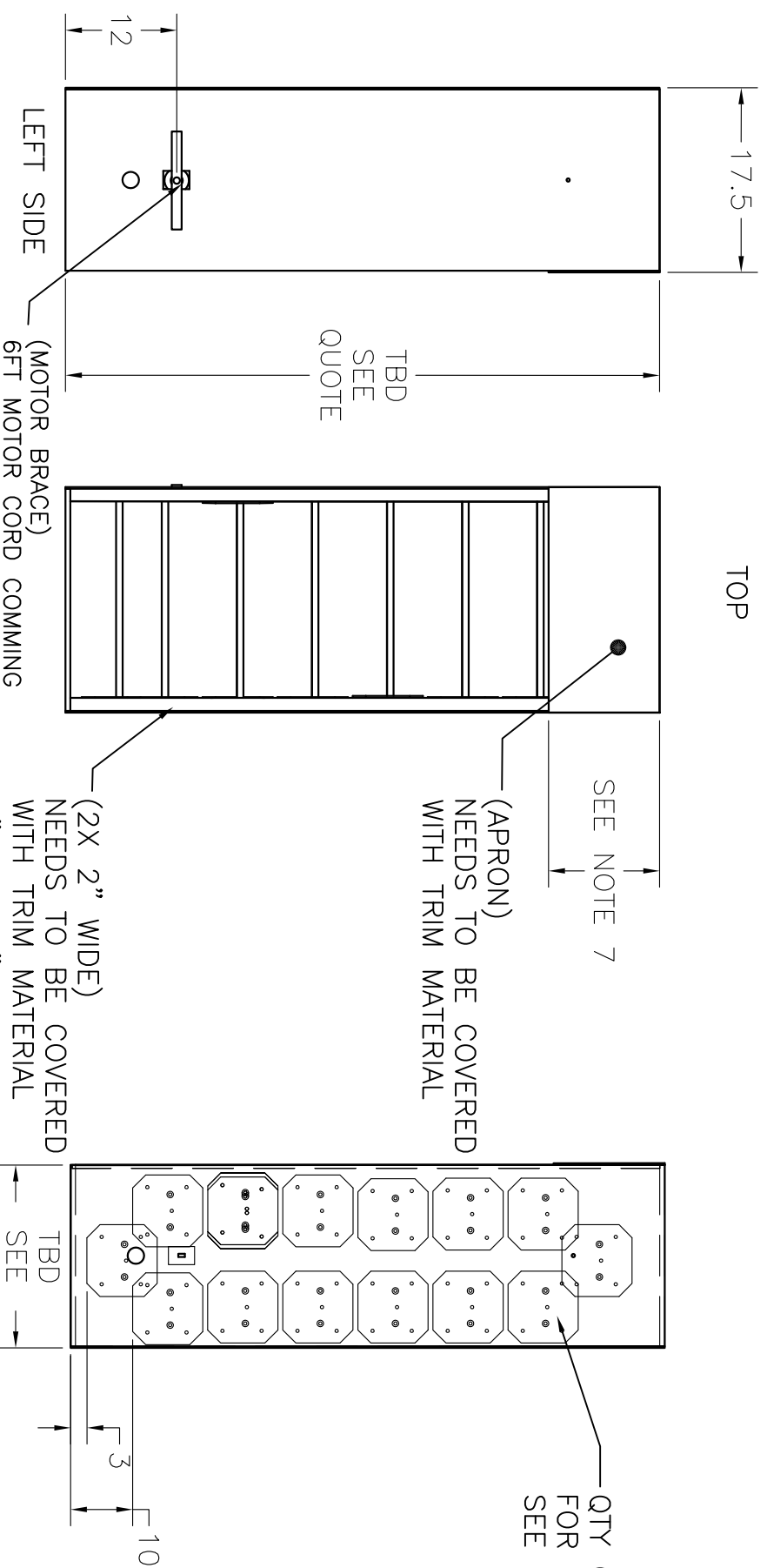

NOTE:

1. OVERALL DIMENSIONS INCLUDE ALL CARRAGE BOLT HEADS, BRACES, SCREW HEADS ECT.
2. UNITS ARE FULLY ASSEMBLED WHEN SHIPPED.
3. 110 VOLT MOMENTARY WALL SWITCH WITH SWITCH PLATE IS PROVIDED AND MUST BE LOCATED OUTSIDE THE UNIT.
4. 2 AMP MOTOR IS LOCATED ON INSIDE OF UNIT BETWEEN THE SHELVES.
5. ONLY THE SHELVES ARE FINISHED. THE INSIDE OF THE UNIT IS PAINTED FLAT BLACK.
6. TRIM MATERIAL/ FACE FRAME MUST BE ADDED THAT MATCHES REST OF CLOSET.
7. SHORT UNITS:14" APRON.
8. TALL UNITS: 24" APRON.
9. ACCESS AREA ON EACH SIDE 18" BY 17" HIGH IS RECOMMENDED.
10. QUANTITY OF SHELVES IS DETERMINED IN QUOTE.
11. INSTALLATION SPACE REQUIRED IS 31" WIDE X 19" DEEP X 170" TALL.

RIGHT SIDE

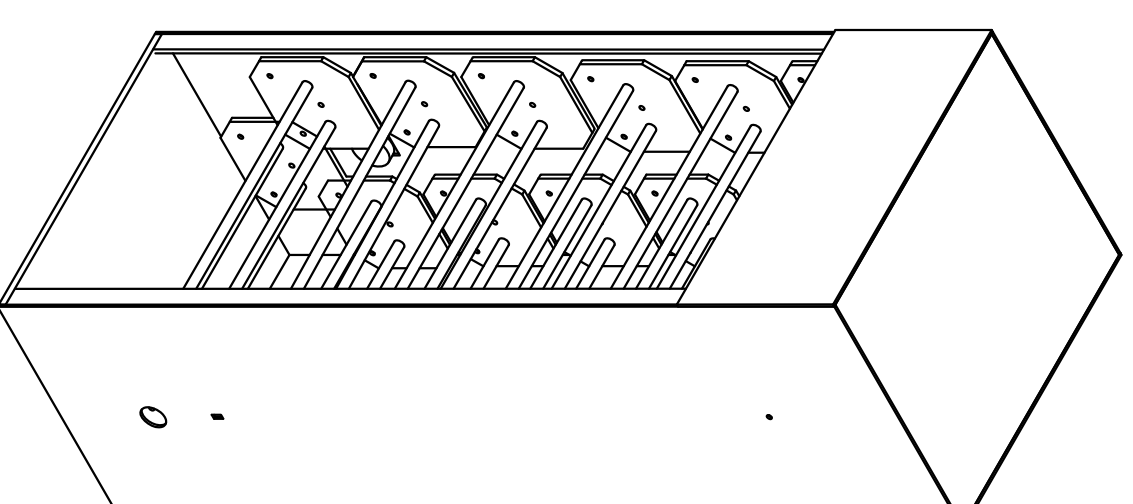

 STORAGEOTION		VERTICAL WINE CAROUSEL 18 SYSTEM		
DRAWN BY: AJA		STORAGEOTION INC. MOORESVILLE NC.		
CHECKED BY: KURT K				
DATE DRAWN:9-13-16				
CHECKED DATE:	SIZE	MATERIAL	DWG NO	REV
UNLESS OTHERWISE SPECIFIED	B	AS BUILT	2016016	-
SCALE	N/A	FINISH	-	SHEET 1 OF 1